

Omnia UL Fan coils

Universal installations for residential applications



Aermec participate in the EUROVENT program: FCH the products are present on the site www.eurovent-certification.com



Variable Multi Flow[®]
VMF



Plasmacluster
(only for Omnia UL PC)

White colour:

- cover: RAL 9002
- top and supports: RAL 7044

Features

- UL (Universal Line) fan coils for both horizontal and vertical installation
- **Versions:**
 - UL-S:** version without switch, with cabinet. Compatible with VMF System
 - UL:** version with switch and cabinet
 - UL-C:** version with electronic thermostat and with cabinet
 - UL-PC:** version with electronic thermostat and Plasmacluster filter (factory-mounted only) and cabinet
- **Versions compatible with VMF System.**
- **Fan cleaning:** Omnia fan coils allow fan blades to be easily cleaned. It is now possible to remove the fan volute (it contains the fan blades) and clean it periodically.
- **Condensate drip tray cleaning:** Thanks to a new drip tray fitting, it is now easier to clean it with Omnia fan coils. This important solution avoids, in the long run, bacteria, germs and mould to grow up, in the drip tray because of the air humidity.
- **Precharged electrostatic filter:** Omnia fan coils have, as standard, precharged electrostatic filters. These filters, thanks to their special execution, attracts and retains all suspended dust particles, thus guaranteeing pure breathable air to the whole family.
- **PLASMACLUSTER ionising filter:** Plasmacluster is capable of reducing the level of pollutants, by decomposing the molecules that form them. Using a series of electric shocks, "Plasmacluster" causes the water molecules present in the air to separate into positive and negative ions. These ions neutralise the gas pollutant molecules, forming products that are normally present in clean air. The result is in the air: you can finally breathe clean, odour-free ionised air.
- **Silent operation:** Thanks to the use of special centrifugal fans, Omnia fan coils operation is extremely silent and offers the maximum acoustic comfort.
- 3-speed centrifugal fan
- Very quiet operation
- Aesthetically styled with soft flowing lines
- Adjustable air delivery louver
- Automatic power-off function with closure of the air delivery louver
- Slim dimensions
- Electronic temperature control, automatic fan speed change, automatic season changeover and automatic on - off (with electronic thermostat)
- Water connections reversibility during installation
- Low pressure drop across heat exchanger
- Motors with permanently connected condensers
- Easy installation and maintenance
- Air filter easy to remove and to clean
- Full compliance with safety regulations

Accessories

- **AMP:** Kit for wall/ceiling mounting. Standard on P and S versions.
- **BC:** Auxiliary condensate drip tray. BC 10 for vertical installation BC 20 for horizontal installation
- **DSC5:** Condensate drainage device for use when natural run-off is not possible. DSC5 is not compatible BC10 - BC20 accessories.
- **GU:** Aspiration grille, covers the front space between the stands, does not interfere with the air filter. **Use with ZU stands compulsory.**
- **PCU:** Rear cover panel.
- **SIT 3-5:** Thermostat interface cards. They allow to set up a fancoils network (max. 10) commanded by a centralised panel (switch or thermostat).
 - SIT3:** commands the three speeds of the fan and must be installed on each fancoil of the network; it receives the commands from the switch or from the SIT5 card.
 - SIT5:** commands the 3 fan speeds and up to two valves (four-pipe systems); it sends the thermostat commands to the fancoils network.
- **SW:** Water probe wich enables automatic season change-over thanks to the specific electronic thermostats.
- **VCH:** Kit comprising motorized 3-way valve, unions and copper pipes.
- **VCHD:** Kit comprising motorized 2-way valve, unions and copper pipes.
- **ZU:** Feet for floor-standing solutions.
- **Control panels and VMF System:** The control panels are described in a separate document.

Omnia UL S C PC	vers.	11	16	26	36
PX2 o PX2C6 (1)	S	•	•	•	•
PXAE	S	•	•	•	•
PXLM	S	•	•	•	•
TPF -TPFW	S	•	•	•	•
WMT05	S	•	•	•	•
WMT10	S	•	•	•	•
VMF-E4X o E4DX	S	•	•	•	•
VMF-E0 o E19	S	•	•	•	•
AMP10	C-PC	•	•	•	•
BC10	Alls	•	•	•	•
BC20	Alls	•	•	•	•
DSC5 (2)	Alls	•	•	•	•
SIT3	S	•	•	•	•
SIT5	S	•	•	•	•
SW3	C-PC	•	•	•	•
VCH	Alls	•	•	•	•
VCHD	Alls	•	•	•	•
ZU	S-C-PC	•	•	•	•

(1) PX2C6, PX2 panel in multiple 6-piece pack, for only wall installation
(2) The DSC5 accessory is not compatible BC10 - BC20 accessories.

Technical data

Omnia UL	11			16			26			36			
	H	M	L	H	M	L	H	M	L	H	M	L	
Fan speed													
Heating Performance													
2 pipe configuration													
Heating capacity (70°C)	(1) kW	2,01	1,46	1,06	2,91	2,12	1,54	4,62	3,83	2,89	5,94	4,87	3,53
Water flow rate	(1) l/h	176	128	93	255	186	135	405	336	254	521	427	310
Pressure drops	(1) kPa	2,0	1,0	1,0	4,0	2,0	1,0	11,0	8,0	5,0	7,0	5,0	3,0
Heating capacity (45°C)	(2) kW	1,00	0,73	0,52	1,44	1,05	0,76	2,29	1,90	1,44	2,95	2,42	1,75
Water flow rate	(2) l/h	174	126	92	251	183	133	399	331	249	513	420	305
Pressure drops	(2) kPa	2,0	1,0	1,0	2,5	2,5	1,5	11,0	8,0	5,0	18,0	12,5	7,0
Cooling Performance													
Total cooling capacity	(3) kW	0,82	0,67	0,53	1,17	0,87	0,69	1,99	1,65	1,26	2,79	2,26	1,63
Sensible cooling capacity	(3) kW	0,68	0,52	0,38	0,96	0,69	0,52	1,61	1,3	0,97	2,00	1,59	1,13
Cooling capacity (latent)	(3) kW	0,14	0,15	0,15	0,21	0,18	0,17	0,38	0,35	0,29	0,79	0,67	0,50
Water flow rate	(3) l/h	145	117	94	206	153	122	349	289	220	487	394	286
Pressure drops	(3) kPa	2,0	1,5	1,0	5,0	3,0	2,2	11,0	8,0	5,0	19,0	13,0	6,8
Fans													
Fan - Centrifugal	n°	1						2					
Air flow rate	m³/h	180	120	80	240	160	110	350	270	190	460	350	240
Sound data													
Sound power level	(4) dB(A)	46	37	31	48	43	34	48	43	35	50	43	34
Sound pressure level	dB(A)	38	29	23	40	35	26	40	35	27	40	33	26
Diameter connections													
Standard coil	Ø	1/2"			1/2"			1/2"			1/2"		
Electrical Features													
Absorbed power	W	18	12	8	32	25	23	35	27	24	42	35	30
Electrical wiring		V3	V2	V1	V3	V2	V1	V3	V2	V1	V3	V2	V1
Power supply		230V~50Hz											

Data in accordance with Regulation EU 2016/2281

H max. speed; M med. speed; L min. speed

(1) Room air 20°C d.b.; Water (in/out) 70°C/60°C;

(2) Room air 20°C d.b.; Water (in/out) 45°C/40°C (EUROVENT)

(3) Room air 27°C d.b./19°C w.b.; Water (in/out) 7°C/12°C (EUROVENT)

(4) Sound power level on the basis of measurements made in compliance with Eurovent 8/2

Sound pressure level (A-weighted) measured indoors with volume V=85m³, reverberation time t = 0.5 s; Direction factor Q = 2; Distance r = 2.5m

Note: For more information, please refer to the program selection and the technical documentation available on the website www.aermec.com

Dimensions (mm)

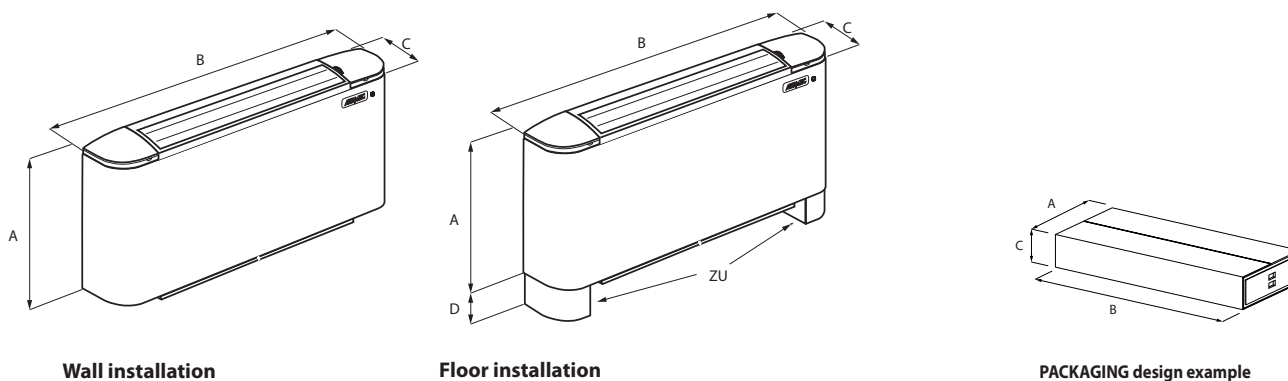

Mod Omnia		UL 11	UL 16	UL 26	UL 36
A		513	513	513	513
B		640	750	980	1200
C		173	173	173	173
D		93	93	93	93
Weight †	kg	12,5	13,5	16,5	19,5
Packaging Dimensions					
A/B/C	mm	590/275/710	590/275/820	590/275/1050	590/275/1270

(†) Standard configuration without accessories

All specifications are subject to change without prior notice. Although every effort has been made to ensure accuracy, Aermec does not assume responsibility or liability for eventual errors or omissions.

Aermec S.p.A.
Via Roma, 996 - 37040 Bevilacqua (VR) - Italia
Tel. 0442633111 - Telefax 044293577
www.aermec.com